

High Spin Industrial Washer Extractors

LH 335, LH 400, LH 550

FEATURES

- Freestanding, high spin
- Stainless steel cabinet (AISI 304)
- Stainless steel drum and tub
- Graphitronic® - new graphic display with almost unlimited possibilities as:
 - Communication interface enabling remote service
 - Multilingual microprocessor
 - Freely programmable
- Large door opening (Ø54 cm) for easy loading and unloading
- Large drain valves (2×Ø76 mm)
- Easy access to all parts
- Standard liquid soap connections
- Frequency controlled motor
- Patented soap dispenser with 5 removable compartments
- PowerWash® perforated lifting ribs: more mechanical action, lower water consumption
- Liquid manifold
- SuperEco washing programmes
 - significantly reduces water and electricity consumption

OPTIONS

- Low steam pressure heating
- Liquid soap pumps
- SoftWash® version (wet cleaning)
- Trace-Tech® traceability software and networking system



TYPE		LH 335	LH 400	LH 550
CAPACITY				
Drum volume	l	335	400	518
Capacity	kg/lb	33/80	40/100	55/125
Drum diameter	mm	Ø914	Ø914	Ø914
MOTOR				
Frequency controlled		standard	standard	standard
DRUM SPEED				
Wash speed	rpm	38	38	38
Spin speed	rpm	830	830	830
G-Factor		350	350	350
PROGRAMMER				
Graphitronic® microprocessor		standard	standard	standard
CABINET				
Stainless steel AISI 304		standard	standard	standard
SAFETY FIXING				
		yes (4xM16)	yes (4xM16)	yes (4xM16)
HEATING				
100% hot water	°C	90	90	90
	°F	194	194	194
100% electrical	kW	24	36	54
Steam high pressure	bar	3-8	3-8	3-8
CONNECTION				
Electrical		3x220-240V 50/60Hz 3x380-480V 50/60Hz Others on request		
Water inlet	inch	1"		
Steam inlet	inch	3/4"		
DIMENSIONS				
HxWxD	mm	1905x1195x1330	1905x1195x1430	1905x1195x1610
TRANSPORT DATA				
Gross weight				
Crate packing	kg	1370	1700	1770
Net weight	kg	1230	1560	1630
Volume (packed)				
Crate packing	m ³	4,4	4,7	5,3
Crate packing HxWxD	mm	2105x1430x1475	2105x1430x1570	2105x1430x1750
WATER CONSUMPTION				
Cold and hot water per cycle*	l	202 + 50	445 + 79	528 + 93

Standard = Standard version, * Tested in accordance of EN 604 56 norm
The data concerning dimensions of machines include all extended parts

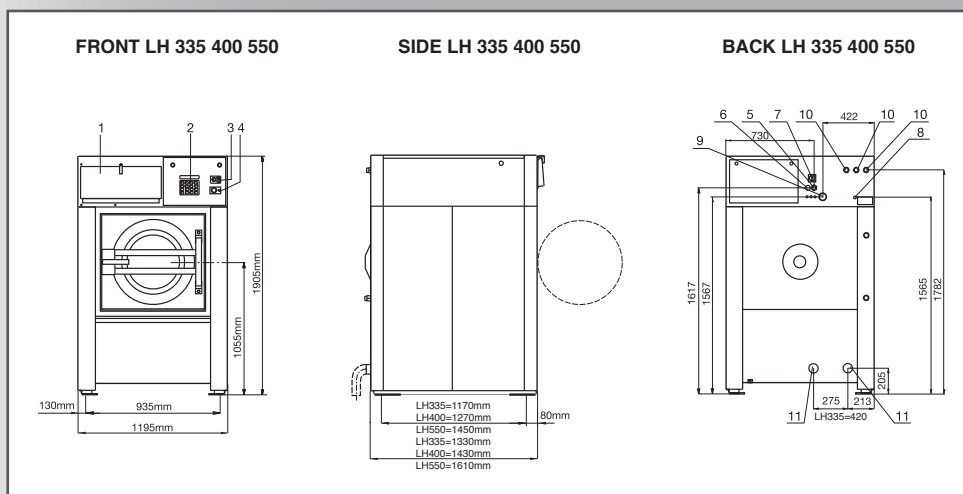

1. Soap hopper
2. Keyboard
3. Keyswitch
4. Emergency stop
5. Electrical connection
6. Electrical connection to liquid soap
7. Main switch
8. Liquid soap pump connections
9. Air vent tub
10. Water connection
11. Drain valve

Lavamac preserves the right to change the machines and the specification in this leaflet at any time, without prior notice. Details and photographs are only for information and never binding.

www.lavamac.eu



05-2010/532445